

GE Energy

# Masoneilan\* Products

## 4700E/4800E Electropneumatic Positioners ATEX Instruction Manual

Corrosion resistant positioner

- Accurate positioning
- Integrated 4000 Series I/P transducer
- Optional high-flow capacity



imagination at work

# CONTENTS

<b>WARNING</b>	<b>3</b>
<b>INSTRUMENT OPERATION</b>	<b>3</b>
1. <b>NUMBERING SYSTEM</b>	<b>4</b>
2. <b>TECHNICAL DATA</b>	<b>4</b>
2.1. <b>Performances</b>	<b>4</b>
2.2. <b>Schematic</b>	<b>4</b>
3. <b>ATEX INTRINSIC SAFETY MARKING and nL TYPE FOR MODEL 4000 I/P CONVERTER</b>	<b>5</b>
4. <b>ATEX EXPLOSIONPROOF MARKING FOR MODEL 4000 I/P CONVERTER</b>	<b>5</b>
5. <b>ELECTRICAL CONNECTIONS and CONDUIT ENTRY</b>	<b>6</b>
5.1. <b>Current signal</b>	<b>6</b>
5.2. <b>Maximum Power</b>	<b>6</b>
5.3. <b>Intrinsic Safety entity parameters</b>	<b>6</b>
5.4. <b>Conduit entry in flameproof application</b>	<b>6</b>
6. <b>ASSEMBLY OF A 4700E OR 4800E POSITIONER ON A VALVE</b>	<b>7</b>
7. <b>PNEUMATIC CONNECTION OF POSITIONER 4700 E / 4800 E</b>	<b>7</b>
8. <b>INSTALLATION and START UP</b>	<b>7</b>
8.1. <b>Installation</b>	<b>7</b>
8.2. <b>Start up</b>	<b>7</b>
9. <b>CALIBRATION OF THE 4700 E/4800 E POSITIONER</b>	<b>8</b>
10. <b>MAINTENANCE SERVICE</b>	<b>8</b>
10.1. <b>General rules</b>	<b>8</b>
10.2. <b>Before maintenance activity</b>	<b>8</b>
10.3. <b>During maintenance activity</b>	<b>8</b>
10.4. <b>After maintenance activity</b>	<b>9</b>
11. <b>SPECIAL CONDITIONS OF USE</b>	<b>9</b>
11.1. <b>For Intrinsic Safety and Flameproof</b>	<b>9</b>
11.2. <b>For Intrinsic Safety</b>	<b>9</b>
11.3. <b>For Flameproof</b>	<b>9</b>

## WARNING

**BEFORE installing, using or carrying out any maintenance tasks associated with this instrument, READ THE INSTRUCTIONS CAREFULLY.**

These instruments comply with the essential safety requirements of the European Directive ATEX 94/9/CE. It is certified to be used in Gas or Dust explosive atmospheres, groups IIA, IIB, IIC or IIIC:

- Category II 1GD – zones 0, 1, 2, 20, 21 and 22 for the protection mode "ia"
- Category II 3G – zone 2 for the protection mode "nA & nL"
- Category II 2GD – zones 1, 2, 21 and 22 for the protection mode "d".

They also comply with the essential safety requirements of the European Directive EMC 89/336/CE as amended, for use within an industrial environment.

It is the end user's responsibility to:

- Verify material compatibility with the application
- Ensure proper use of fall protection when working at heights, per Safe Site Work Practices
- Ensure use of proper Personal Protective Equipment
- Take the appropriate actions to ensure that site personnel who are performing installation, commissioning and maintenance have been trained in proper site procedures for working with and around equipment, per Safe Site Work Practices

Products certified as **explosion proof equipment MUST BE:**

- a) Installed, put into service, used and maintained in compliance with European and/or national and local regulations and in accordance with the recommendations contained in the relevant standards concerning potentially explosive atmospheres.
- b) Used only in situations those comply with the certification conditions shown in this document and after verification of their compatibility with the zone of intended use and the permitted maximum ambient temperature.
- c) Installed, put into service and maintained by qualified and competent professionals who have been trained in proper site procedures for instrumentation used in areas with potentially explosive atmosphere and for working with and around equipment, per Safe Site Work Practices.

Under certain operating conditions, the use of damaged instruments could cause a degradation of the performances of the system which may lead to personal injury or death.

Use only genuine replacement parts, which are provided by the manufacturer, to guarantee that the products comply with the essential safety requirements of the European Directives mentioned above.

### INSTRUMENT OPERATION

- 4700E/4800E apparatus: electro pneumatic positioner (force balanced principle) with integrated current to pressure converter (4000 I/P Converter). It controls the position of the plug of a control valve to a 4-20 mA control signal. Feedback is obtained by means of a cam.
- 4800E is a positioner with a high flow pneumatic block.

## 1. NUMBERING SYSTEM

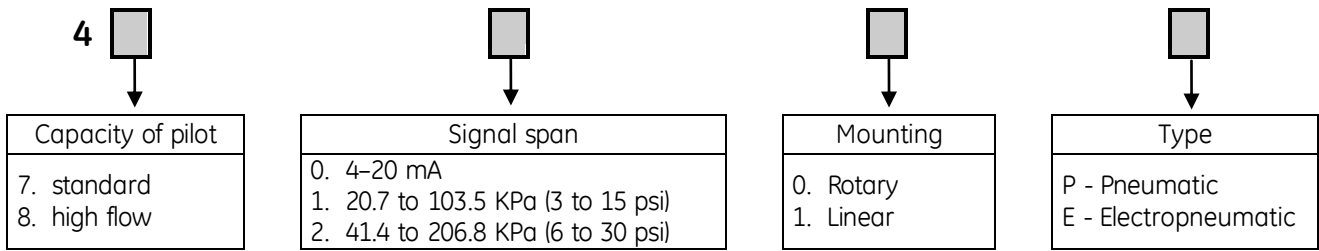

## 2. TECHNICAL DATA

### 2.1. Performance

Performance (% of the signal range)	4700E	4800E
Dead Zone	< 0.5	< 0.5
Hysteresis	< 0.5	< 0.8
Repeatability	0.5	0.5
Sensitivity	0.3	0.5
Conformity	± 1	± 1
Input impedance	170 ohms	170 ohms

- Maximum service temperature range: (refer to the marking on the apparatus).  
Standard Instrument: - 40 °C to + 85 °C (-40°F to +185°F)
- Storage temperature: - 55°C to + 90°C (-67°F to + 194°F)
- The components of the I/P Module are protected by a metallic housing. Housing electrical protection index: IP 66.

### 2.2. Schematic

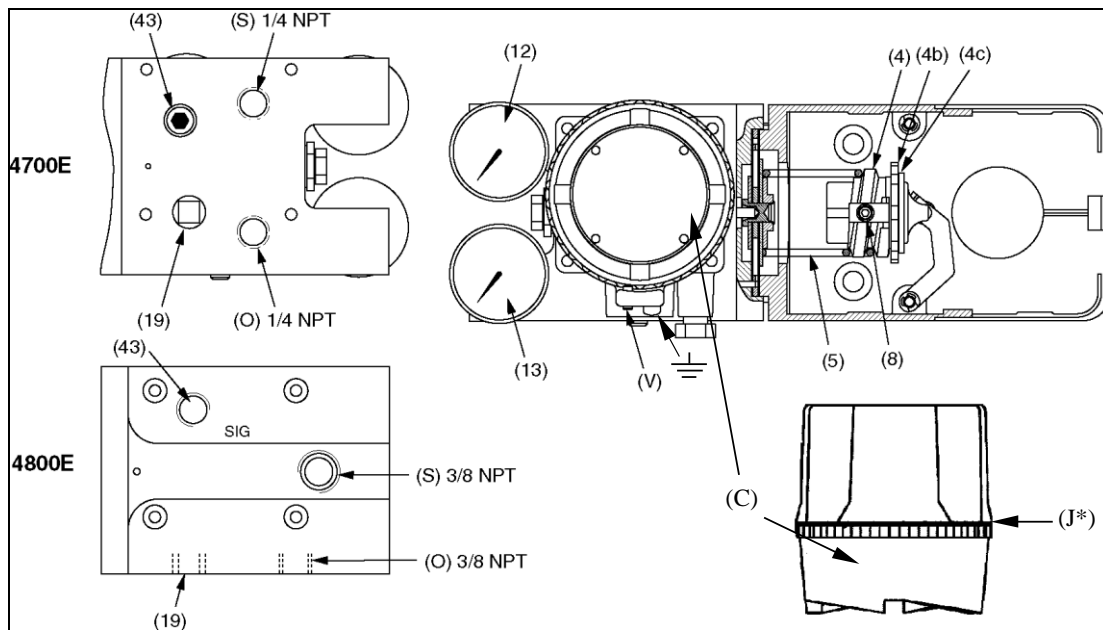



REP.	Designation	REP.	Designation	REP.	Designation
4	Spring end	12	Supply gauge	C	Cover
4b	Zero nut	13	Output gauge	J (*)	O'ring seal
4c	Zero lock nut	19	Vent plug	O	Output
5	Feedback spring	43	Plug	S	Supply
8	Socket head screw			V	Safety screw

\* O'ring seal is not visible.

### 3. ATEX INTRINSIC SAFETY MARKING and nL TYPE FOR MODEL 4000 I/P CONVERTER

The marking is on the serial plate stamped on the I/P Converter housing

- Masoneilan Dresser Inc
- 85 Bodwell Street Avon Massachusetts USA.
- MODEL 4000 I/P CONVERTER
- SIRA 02ATEX2277X ("ia" protection mode)
- SIRA 02ATEX4279X (« nA nL » protection mode)
- (Serial number)
- The two first digits of the serial number indicate the year of manufacture: 11 = 2011, 12 = 2012, etc ...
- $U_i = 30 \text{ Vdc}$ ,  $I_i = 110 \text{ mA}$ ,  $L_i = 0$ ,  $C_i = 0$ .
- IP66
- Notified body CE \*\*\*\*
-  II 1GD  
Ex ia IIC T4 Ga ( $T_a = -40^\circ\text{C}$  to  $+80^\circ\text{C}$ ,  $P_i = 1.1\text{W}$ )  
Ex ia IIC T6 Ga ( $T_a = -40^\circ\text{C}$  to  $+55^\circ\text{C}$ ,  $P_i = 0.33\text{W}$ )  
Ex ia IIIC Da T90°C ( $T_a = -40^\circ\text{C}$  to  $+80^\circ\text{C}$ ,  $P_i = 1.1\text{W}$ )
-  II 3G  
Ex nA nL IIC T4 Gc  $T_a = -40^\circ\text{C}$  to  $+80^\circ\text{C}$
- Warning:  
Potential electrostatic charging hazard.  
See instructions for safe use.

### 4. ATEX EXPLOSIONPROOF MARKING FOR MODEL 4000 I/P CONVERTER

The marking is on the serial plate stamped on the I/P Converter housing

- Masoneilan Dresser Inc
- 85 Bodwell Street Avon Massachusetts USA.
- MODEL 4000 I/P CONVERTER
- SIRA 02ATEX1274
- (Serial number)
- The two first digits of the serial number indicate the year of manufacture: 11 = 2011, 12 = 2012, etc ...
- $P_i = 0.8 \text{ W}$
- IP66
- Notified body CE \*\*\*\*
-  II2GD  
Ex d IIC T6 Gb             $T_a : -40^\circ\text{C}$  to  $+55^\circ\text{C}$   
Ex d IIC T5 Gb             $T_a : -40^\circ\text{C}$  to  $+70^\circ\text{C}$   
Ex d IIC T4 Gb             $T_a : -40^\circ\text{C}$  to  $+85^\circ\text{C}$   
Ex t IIIC T90°C Db         $T_a : -40^\circ\text{C}$  to  $+55^\circ\text{C}$
- Warning:  
Do not open when energised.  
Do not open when an explosive gas atmosphere is present.  
Potential electrostatic charging hazard.  
See instructions for safe use.  
Use cables rated to  $\geq 5^\circ\text{C}$  above ambient.

## 5. ELECTRICAL CONNECTIONS and CONDUIT ENTRY

- ☞ Comply with current national and local regulations for electrical installation work.
- ☞ Comply with national and local explosive atmosphere regulations.
- ☞ Before carrying out any work on the device, power off the instrument or make sure that the local conditions in the potentially explosive atmosphere permit the safe opening of the cover.
- ☞ Before switching on or after doing any work on the device, always tighten the cover (C) with a seal (J) in good condition and put back the safety screw (V).

The Model 4000 I/P Converter must be installed and put into service in conformance with **EN/IEC 60079-14**, **EN/IEC 61241-14** and / or national and local regulations applicable for explosive atmospheres.

### 5.1. Current signal

The Model 4000 I/P Converter is self-powered 4-20mA current receiver. Connect the wires to the instrument's terminals, taking care of complying with polarities + and - .  
Make the earth connections with the internal and external ground terminals.

- Input signal: 4-20 mA,
- Input impedance: 170 ohms.

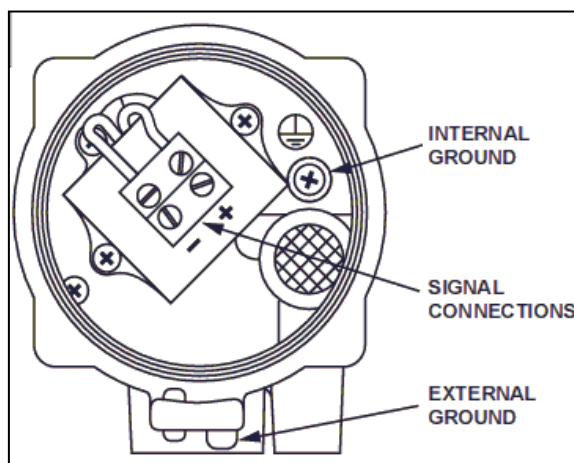

### 5.2. Maximum Power

- 0.8 W for Flameproof atmosphere
- 1.1W or 0.33W for Intrinsic Safety atmosphere

### 5.3. Intrinsic Safety entity parameters

Entity parameters		T4	T6	Unit
Max. Input Voltage	U <sub>i</sub>	30	30	V
Max. Input Current	I <sub>i</sub>	110	110	mA
Max. Input Power	P <sub>i</sub>	1100	0.33	mW
Max. Internal Capacitance	C <sub>i</sub>	0	0	nF
Max. Internal Inductivity	L <sub>i</sub>	0	0	μH

### 5.4. Conduit entry in flameproof application

The connections can be done with different variations taking into account approved manufacturer and requested approvals:

- A cable entry of a certified type Ex d IIC / Ex tD A21 or Ex t IIC Db can be mounted directly on the single ½" NPT (**ANSI/ASME B1.20.1**) housing conduit connection or M20 (**ISO965-1 & ISO965-3**).
- For identification machining thread, check the part number stucked on the Model 4000 I/P Converter body:

M20	00-055100106-888
½ NPT	00-055100212-888

- Adaptors or reducers if apparatus certified ATEX or IECEx.

## 6. ASSEMBLY OF A 4700E OR 4800E POSITIONER ON A VALVE

- ☞ Comply with current national and local regulations for electrical installation work.
- ☞ Comply with national and local explosive atmosphere regulations.
- ☞ Before carrying out any work on the device, power off the instrument or make sure that the local conditions in the potentially explosive atmosphere permit the safe opening of the cover.
- ☞ Before switching on or after doing any work on the device, always tighten the cover (C) with a seal (J) in good condition and put back the safety screw (V).

**Note:** Before installation, check that the device is undamaged. In the event of damage, inform the manufacturer whose address is shown on the serial plate;

If the positioner is supplied mounted on a valve, GE Energy installs it, make the pneumatic connection and configure and calibrate it.

When the positioner is shipped alone, the user is responsible for its installation, electrical and pneumatic connections and its calibration.

Please refer to operating instruction manual GEA19730 for more detail.

## 7. PNEUMATIC CONNECTION OF POSITIONER 4700 E / 4800 E

- ☞ Make sure that the air supply pressure is suitable for the installation and for the instrument.
- ☞ When using a positioner make sure that the air supply pressure matches the one specified on the serial plate without exceeding 700 kPa (100 psi).

- If the instrument has been shipped alone, make pneumatic connections as per § 2.2: air supply pressure to input (S) and output (O) to the actuator.
- Minimum diameter of tubing:
  - 4700 E : 4 x 6 mm
  - 4800 E : 10 x 12 mm

## 8. INSTALLATION and START UP

- These operations must be put into service in conformance with **EN/IEC 60079-17** and / or national and local regulations applicable for explosive atmospheres.
- Before carrying out any work on the device, check that the local conditions in the potentially explosive atmosphere zone permit the safe opening of the covers.

### 8.1. Installation

- Explosionproof instrument can be installed in flammable gas explosive atmosphere groups IIA, IIB, IIC for the zones 1 and 2 or in flammable dust explosive atmosphere group IIIC zones 21 and 22.
- Intrinsically safe instrument can be installed in flammable gas explosive atmospheres groups IIA, IIB, IIC for the zones 0, 1 and 2 or in flammable dust explosive atmosphere group IIIC zones 20, 21 and 22.
- Note: Since the apparatus has a multiple certifications: ia, d, nA or nL, it is recommended that the type of installation Ex ia, Ex d, Ex nA nL is identified on or next to the apparatus.

### 8.2. Start up

**NOTE:** Before start up, proceed, if required, with instrument calibration as per § 9 and/or ensure that all the safety instructions in the preceding paragraphs have been strictly followed.

- ☞ Before switching on or after doing any work on the device, always tighten the cover (C) with a seal (J) in good condition and put back the safety screw (V).
- ☞ Check that the cable gland is certified for the intended use and that the electrical data are suitable for the operating zone.

## 9. CALIBRATION OF THE 4700 E/4800 E POSITIONER

- ☞ Comply with current national and local regulations for electrical installation work.
- ☞ Comply with national and local explosive atmosphere regulations.
- ☞ Before carrying out any work on the device, power off the instrument or make sure that the local conditions in the potentially explosive atmosphere permit the safe opening of the cover.
- ☞ Before switching on or after doing any work on the device, always tighten the cover (C) with a seal (J) in good condition and put back the safety screw (V).

The positioner mounted on the valve is factory calibrated. If it is supplied alone, calibration will be carried out by the customer, as follows:

- Make the electrical and pneumatic connections, see § 5 and § 7.
- The zero is set using the nut (4b). Adjust the nut (4b) so that the valve is close for the signal value that corresponds to the closure of the valve.
- The span is adjusted using the spring (5). Turn the spring (5) on the spring end (4), to increase or reduce the number of active coils, thus reducing or increasing the stiffness of the spring. These operations are carried out to adjust the span so as that the valve describes its entire stroke for the full range of the control signal.
- These two operations are repeated until the correct settings are obtained.
- Lock the zero lock nut (4c) and the socket head screw (8)

**Note: the Model 4000 I/P Converter does not require any adjustment.**

## 10. MAINTENANCE SERVICE

- ☞ Comply with current national and local regulations for electrical installation work.
- ☞ Comply with national and local explosive atmosphere regulations.
- ☞ Before carrying out any work on the device, power off the instrument or make sure that the local conditions in the potentially explosive atmosphere permit the safe opening of the cover.
- ☞ Before switching on or after doing any work on the device, always tighten the cover (C) with a seal (J) in good condition and put back the safety screw (V).

### 10.1. General rules

These operations must be put into service in conformance with **EN/IEC 60079-17** and / or national and local regulations applicable for explosive atmospheres.

### 10.2. Before maintenance activity

Before carrying out any work on the device, check that the local conditions in the potentially explosive atmosphere zone permit the safe opening of the cover (C).

### 10.3. During maintenance activity

Take into account all special conditions of use points listed § 11.

Pay particular attention to the following points:

- Check that no part is damaged. In the event of damage, replace the defective parts with genuine manufacturer's replacement parts only.
- Check the general condition of the main cover seal (C) and the housing.
- Check the gland and the electrical connections.
- Check the pilot:
  - Disconnect the air supply and remove the pilot from the pneumatic block
  - After disassembly of the pilot (see picture below) clean parts and blow air through the ports and tubing.
  - The reassembly of the pilot is done in accordance with the figure below by using three new O rings.
  - Screw the assembly in the pneumatic block.



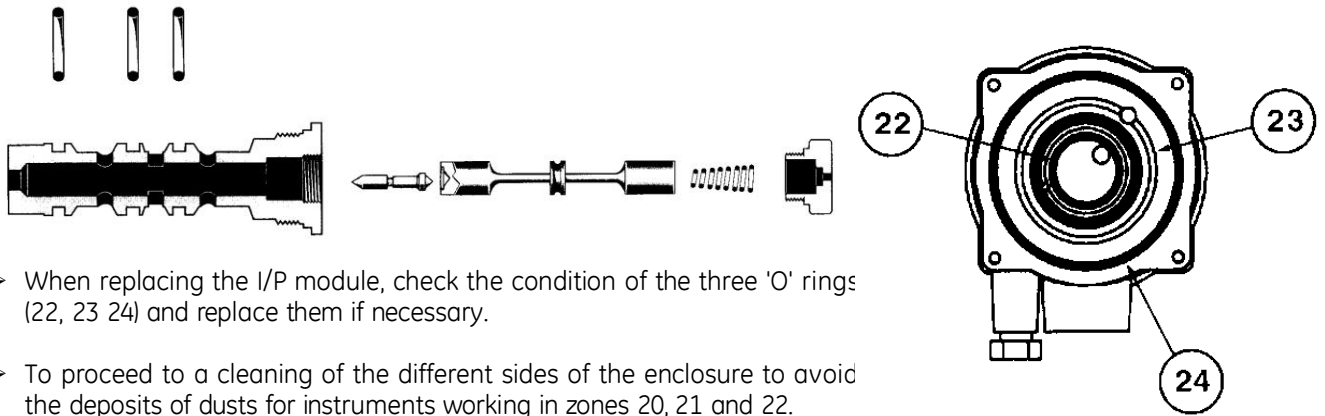

- When replacing the I/P module, check the condition of the three 'O' rings (22, 23 24) and replace them if necessary.
- To proceed to a cleaning of the different sides of the enclosure to avoid the deposits of dusts for instruments working in zones 20, 21 and 22.
- Avoid contact of the apparatus with aggressive substances which could damage the metallic or plastic parts.

#### 10.4. After maintenance activity

After doing any work on the device, check the cover (C) is fully screwed and the security cover screw is well locked (V).

## 11. SPECIAL CONDITIONS OF USE

### 11.1. For Intrinsic Safety and Flameproof

- It is under the user responsibility to check once a year the gasket and in the event of damage to replace the defective parts with manufacturer's replacement parts only.
- For use in dusty hazardous areas, the user will have to proceed to a cleaning regularly the different sides of the enclosure to avoid the deposits of dusts, the maximum thickness must be <5 mm. For safe operation, this can be done only if the local conditions around the device are free of potentially explosive atmosphere.
- The user will have to check the temperature increase on the positioner coming from the mechanical part in contact with or through the process thermal radiation be less or equal than the temperature classification allowed. This must be done in conformance with **EN/IEC 60079-14** and / or national and local regulations applicable for explosive atmospheres.
- The user will proceed a cleaning of the device and mainly the plastic label with a wet rag to avoid any electrostatic spark. For safe operation, this can be done only if the local conditions around the device are free of potentially explosive atmosphere.

### 11.2. For Intrinsic Safety

- The cable entry must have a protection level at least equal to **IP54** according to **EN/IEC 60529** standards.
- For the housing with aluminum material, the user will have to determine the use of the device for group II category 1 (zone 0) against potential inflammable source causing by sparks in the event of impact or friction.
- The current source supply connected on the Model 4000 connectors must be certified for use in group IIC and intrinsic safety loop approved. The entity parameters of the current source supply must be compatible with the entity parameters of the Model 4000 I/P Converter described § 5.3.

### 11.3. For Flameproof

- For ambient temperature greater than 70°C, the user must choice a cable entry and a cable compatible with:

Ambient Temperature	Cable and Cable Entry Temperature
70 °C	75 °C
85 °C	90 °C

- The cable entry and the cable must be compatible with the minimum temperature of -40°C indicated on the marking plate.
- The cable entry must have a protection level at least equal to **IP66/67**.

# DIRECT SALES OFFICE LOCATIONS

## BELGIUM

Phone: +32-2-344-0970  
Fax: +32-2-344-1123

## BRAZIL

Phone: +55-11-2146-3600  
Fax: +55-11-2146-3610

## CANADA

Ontario  
Phone: +905-335-3529  
Fax: +905-336-7628

## CHINA

Phone: +86-10-8486-4515  
Fax: +86-10-8486-5305

## FRANCE

Courbevoie  
Phone: +33-1-4904-9000  
Fax: +33-1-4904-9010

## GERMANY

Viersen  
Phone: +49-2162-8170-0  
Fax: +49-2162-8170-280

## INDIA

Mumbai  
Phone: +91-22-8354790  
Fax: +91-22-8354791

## New Delhi

Phone: +91-11-2-6164175  
Fax: +91-11-5-1659635

## ITALY

Phone: +39-081-7892-111  
Fax: +39-081-7892-208

## JAPAN

Chiba  
Phone: +81-43-297-9222  
Fax: +81-43-299-1115

## KOREA

Phone: +82-2-2274-0748  
Fax: +82-2-2274-0794

## MALAYSIA

Phone: +60-3-2161-0322  
Fax: +60-3-2163-6312

## MEXICO

Phone: +52-5-310-9863  
Fax: +52-5-310-5584

## THE NETHERLANDS

Phone: +0031-15-3808666  
Fax: +0031-18-1641438

## RUSSIA

Veliky Novgorod  
Phone: +7-8162-55-7898  
Fax: +7-8162-55-7921

## Moscow

Phone: +7 495-585-1276  
Fax: +7 495-585-1279

## SAUDI ARABIA

Phone: +966-3-341-0278  
Fax: +966-3-341-7624

## SINGAPORE

Phone: +65-6861-6100  
Fax: +65-6861-7172

## SOUTH AFRICA

Phone: +27-11-452-1550  
Fax: +27-11-452-6542

## SOUTH & CENTRAL

AMERICA AND THE CARIBBEAN  
Phone: +55-12-2134-1201  
Fax: +55-12-2134-1238

## SPAIN

Phone: +34-93-652-6430  
Fax: +34-93-652-6444

## UNITED ARAB EMIRATES

Phone: +971-4-8991-777  
Fax: +971-4-8991-778

## UNITED KINGDOM

Wooburn Green  
Phone: +44-1628-536300  
Fax: +44-1628-536319

## UNITED STATES

Massachusetts  
Phone: +1-508-586-4600  
Fax: +1-508-427-8971

## Corpus Christi, Texas

Phone: +1-361-881-8182  
Fax: +1-361-881-8246

## Deer Park, Texas

Phone: +1-281-884-1000  
Fax: +1-281-884-1010

## Houston, Texas

Phone: +1-281-671-1640  
Fax: +1-281-671-1735

## California

Phone: +1-562-941-7610  
Fax: +1-562-941-7810



\* Masonellan, Camflex, Varimax, and MiniTork are registered trademarks of the General Electric Company. Other company names and product names used in this document are the registered trademarks or trademarks of their respective owners.

© 2012 General Electric Company. All rights reserved.

GEA19513 March 2012