

# Becker\* Rotary Piston Double Acting (RPDA)

Heavy -duty, high performance applications require RPDA Actuators

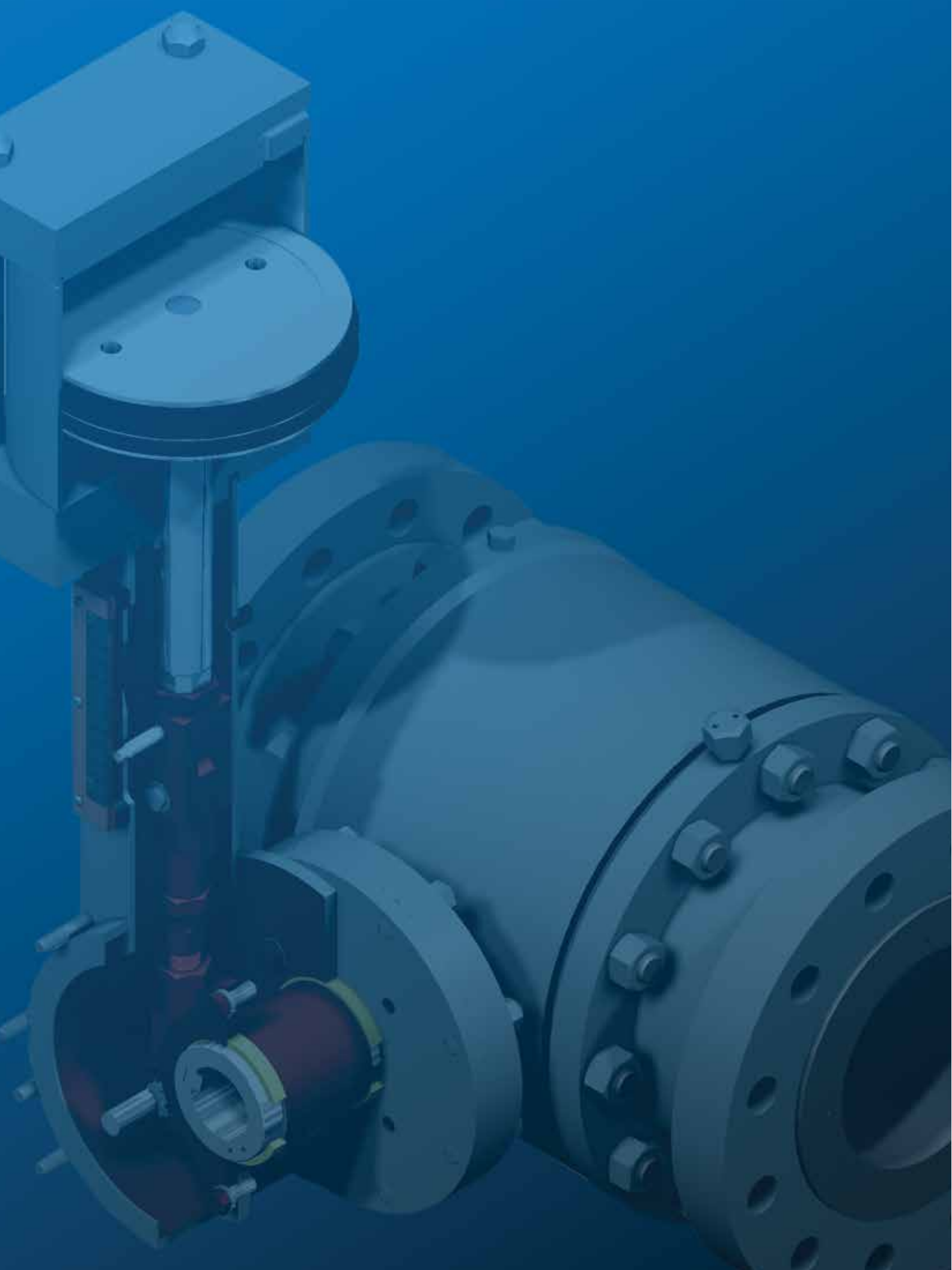



Becker RPDA Rotary Piston Double Acting Actuators from GE Oil & Gas are ideally suited for operations that demand a lock last failure mode, including below ground regulation and bleed-to-pressure applications. These long-lasting, compact, durable, and maintenance free actuators can be retrofitted onto almost all pipeline valves. RPDA Actuators are built to accept high pressure power gas and can incorporate options that eliminate emissions and economically reduce below-ground noise.

#### Features

- Bleed to Pressure System\* can eliminate bleed gas emissions
- Retrofits to almost any pipeline valve
- High pressure RPDA actuator accepts high pressure natural gas up to 500 psig (3447 kPa).
- Upright actuator design saves space and promotes longer actuator piston seal life
- Designed to be maintenance free
- Comes equipped with a precision linear scale that indicates valve position in ten degree increments.
- Crank-arm design actuators are specifically suited for control valve applications
- May be mounted in any installation orientation

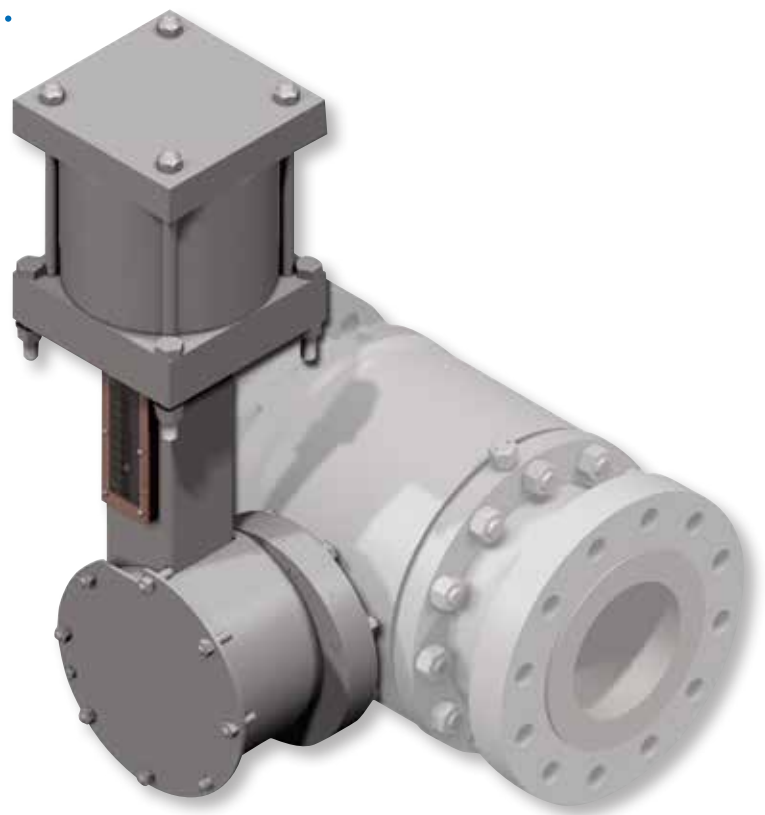

### Technical Specifications

<b>Actuator Mechanism Type</b>	Pneumatic crank arm
<b>Rotation (Output)</b>	90° (standard)
<b>Actuator Stops</b>	Integral
<b>Installation</b>	Vertical (recommended), Horizontal
<b>Coating</b>	Epoxy (standard)
<b>Power Gas Requirements</b>	Sweet natural gas
<b>Maximum Power Gas</b>	500 psig (3447 kPa) Models 10L and smaller 4 50 psig (3103 kPa) Models 12L and larger
<b>Minimum Power Gas</b>	50 psig(345 kPa) recommended
<b>Operating Temperature Range</b>	-20°F to +160°F (-29°C to +71°C) standard, -30°F to +160°F (-34°C to +71°C) (Optional low temp. spec.)
<b>Torque Output</b>	See Table 7
<b>Dimensions</b>	See Tables 3, 4, and 5
<b>Sweet Natural Gas Specification</b>	Filtered to 100μ nominal. Free of excessive moisture (< 7 lbs. entrained H <sub>2</sub> O per 1.0 mmscf) and liquid hydrocarbons.

If excessive moisture or hydrocarbon content is present, a Filter-Dryer may be necessary. For adequate filtration and elimination of moisture, a Becker Model FD-1500 Filter-Dryer should be installed. Refer to Becker FD-1500 literature to determine if a Model FD-1500 Filter-Dryer is necessary.



**Figure 2 - Becker RPDA Actuated Control Valves**

A pressure control regulator station is shown here with Becker RPDA actuators and T-Ball Control Valves. The RPDA actuators are equipped with Becker VRP-CH Valve Regulator Pilots (VRP). The VRP is capable of providing extremely accurate pressure control with fast response necessary for power plant type applications. Additionally, note that the VRP-CH pressure control pilots are equipped with Model VB-250 Volume Boosters to increase stroking speed. The primary regulator is equipped with a QTCV-T2 Quiet Trim Control Valve to provide decreased noise during operation. The monitor regulator is equipped with a FPCV-T0 Full Port Control Valve that ensures bubble tight shut-off with class VI shutoff.

## RPDA Rotary Piston Double Acting Actuator Components

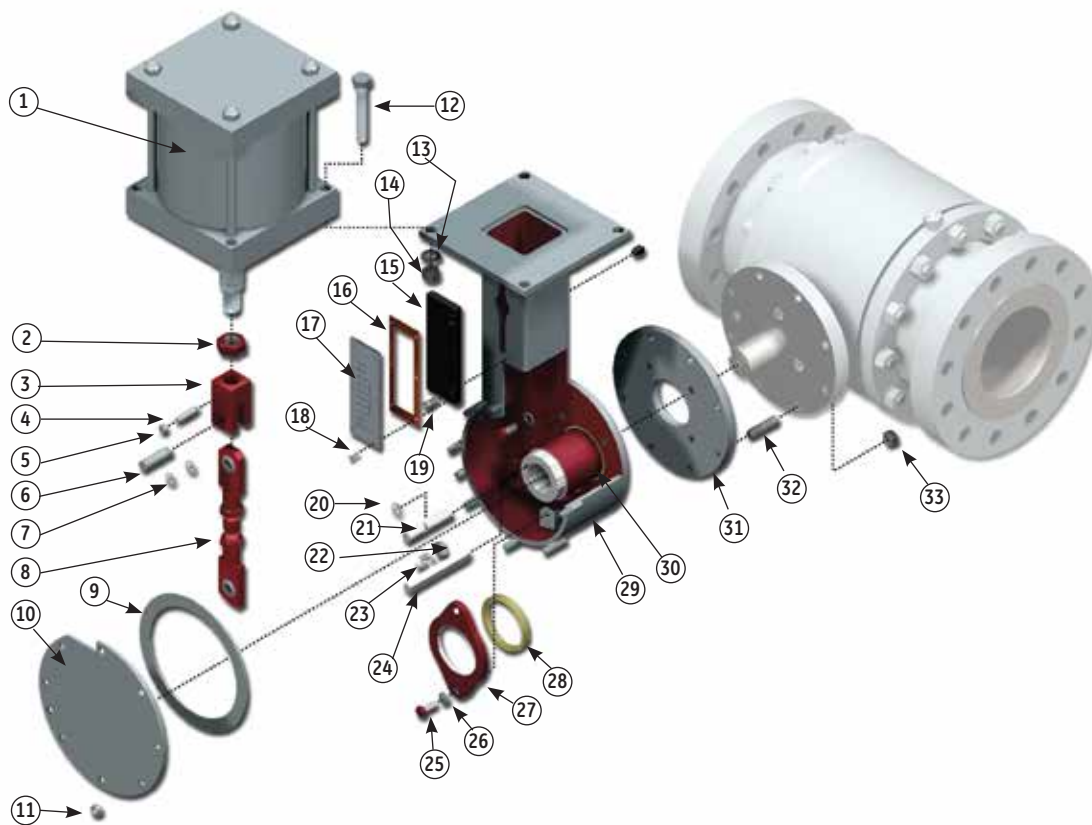

**Table 1** - RPDA Rotary Piston Double Acting Actuator parts description and materials

Item	Description	Material	Item	Description	Material
1	Cylinder	Carbon Steel	18	Indicator Screw	Stainless Steel
2	Jam Nut	Carbon Steel	19	Indicator Frame Screw	Carbon or Stainless Steel
3	Rod Clevis	Carbon Steel	20	Tru-Arc Ring	Carbon Steel
4	Indicator Bar	Stainless Steel	21	Torque Arm Pin	Stress Proof Steel
5	Position Indicator	Aluminum	22	Pin Clamp	Carbon Steel
6	Rod Clevis Pin	Stress Proof Steel	23	Pin Clamp Hardware	Carbon Steel
7	Tru_Arc Ring	Carbon Steel	24	Square Key	Carbon Steel
8	Connecting Link	Carbon Steel	25	Outboard Bearing Belt	Carbon Steel
9	Cover Plate Gasket	Rubber	26	Outboard Bearing Washer	Carbon Steel
10	Cover Plate	Carbon Steel	27	Outboard Bearing Plate	Carbon Steel
11	Cover Plate Nut	Carbon Steel	28	Outboard Bearing	Duralon®
12	Cylinder Bolt	Carbon Steel	29	Actuator Housing	Carbon Steel
13	Cylinder Lockwasher	Carbon Steel	30	Torque Arm	Carbon Steel
14	Cylinder Nut	Carbon Steel	31	Adapter Plate	Carbon Steel
15	Indicator Frame	PVC	32	Stud	Carbon Steel
16	Indicator Gasket	Rubber	33	Nut	Carbon Steel
17	Lexan Cover	Lexan	34	Vent Elbow	Plastic

## Becker RPDA Rotary Piston Double Acting Actuator Cylinder Components

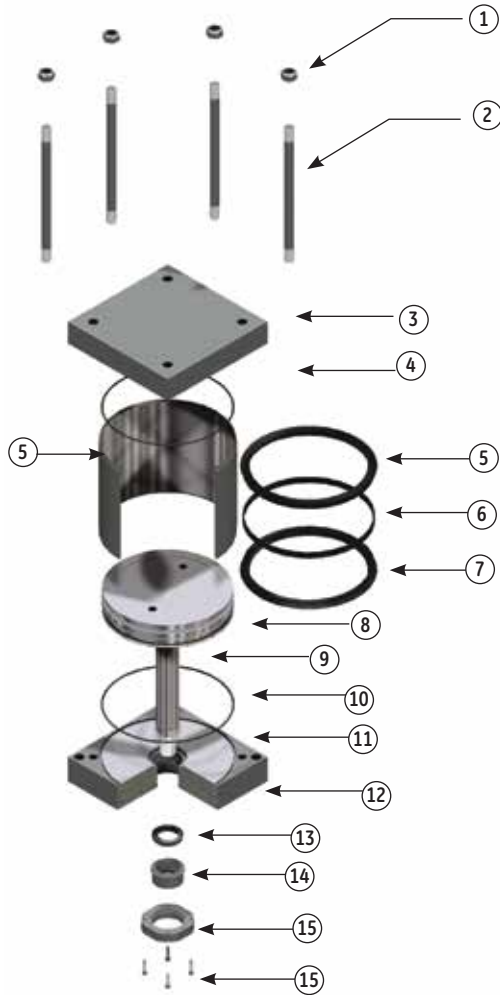

**Figure 4** - RPDA Rotary Piston Double Acting Actuator Cylinder Exploded View

**Table 2** - Components & Materials for construction of RPDA Rotary Piston Double Acting Actuator Cylinder

Item	Description	Material
1	Hex Nut	Steel
2	Cylinder Tie-Rod	High Strength Steel
3	Piston Head (top)	Steel
4	Tube Seal (top)	Buna-N O-Ring
5	Piston U-Cup Seal (top)	Buna-N
6	Rod Clevis Pin	Stress Proof Steel
7	Piston Wear Strip	Reinforced Teflon®
8	Piston	Nodular Iron
9	Piston Rod	Hard Chrome Plated Steel
10	Tube Steel (bottom)	Buna-n O-Ring
11	Piston Head (bottom)	Steel
12	Piston Rod Seal	Polyurethane
13	Piston Rod Bearing	Duralon®
14	Gland Plate	Steel
15	Gland Plate Screws (SHCS)	Alloy Steel
16	Piston Tube	Alloy Steel

Teflon is a registered trademark of Dupont Company  
Duralon is a registered trademark of Rexnord, Inc.

## RPDA Actuators Standard Mounting Configurations



**Figure 5.1**  
Mount #1 - Left Hand (Standard) with clean sweep feature  
Actuator located on left hand side of valve when looking in direction of flow (actuator vertical/valve stem horizontal).



**Figure 5.2**  
Mount #2 - Right Hand  
Actuator located on right hand side of valve when looking in direction of flow (actuator vertical/valve stem horizontal).



**Figure 5.3**  
Mount #3 - Vertical Stem (Actuator Downstream)  
Actuator located on downstream side of valve when looking in direction of flow (actuator horizontal/valve stem vertical).



**Figure 5.4**  
Mount #4 - Vertical Stem (Actuator Upstream)  
Actuator located on up-stream side of valve when looking in direction of flow (actuator horizontal/valve stem vertical).



# RPDA high pressure actuator built solid for all your control valve needs

## Bleed to Pressure System\* Can Eliminate Bleed Gas Emissions

GE's Becker RPDA Actuators feature the unique ability to incorporate the Bleed to Pressure System feature. GE's Becker RPDA Actuators and control instrumentation can accept high pressure power gas and discharge bleed gas to lower pressure systems. Bleed to Pressure System eliminates all atmospheric emissions!

## Maintenance Free

The RPDA actuator is designed to be maintenance free, no regular lubrication is required for the piston cylinder or the actuator mechanism.

## High Pressure Capability

The RPDA actuator is specifically constructed to accept high pressure natural gas up to 500 psig (3448 kPa). Higher pressure power gas allows use of smaller actuators and implementation of Becker products' unique Bleed to Pressure System.

## Vertical Advantage

Upright actuator promotes longer actuator piston seal life, saves space, and requires less maintenance than other actuators.

## Easy to Read Travel Indicator

All RPDA actuators come equipped with a precision linear scale that indicates valve position in ten percent increments.

## Crank Arm Designed for Control Valves

Crank arm design actuators are specifically suited for control applications. The crank arm provides an increasing torque curve that develops high torque output where it counts. Additionally, the crank arm design minimizes friction and lost motion.

## Torque Arm Bearings

RPDA Actuators feature two large Torque Arm Bearings to eliminate side load to control valve stem. Both inboard and outboard torque arm bearings are manufactured from non-metallic Duralon™ material to ensure maximum load bearing capacity.

Duralon is a registered trademark of Rexnord, Inc.

## Below Ground Actuator Option Reduces Noise Attenuation up to 37 dBA

Becker RPDA actuators are available with a unique below ground option that provides superior noise attenuation in regulator stations at minimal cost. Additionally, below ground stations minimize ambient heat loss by maintaining piping systems below ground.

## We can retrofit to almost any valve in your pipeline

We can provide high quality actuators to mate to almost any quarter turn valve, regardless of manufacturer or age. We have years of experience successfully adapting our actuators to fit a multitude of valves.

## U-Cup Seals

U-cup Piston Seals are designed to provide superior sealing capabilities with minimal friction. This design allows accurate positioning of the control valve actuator with very slight pressure differential to the piston.

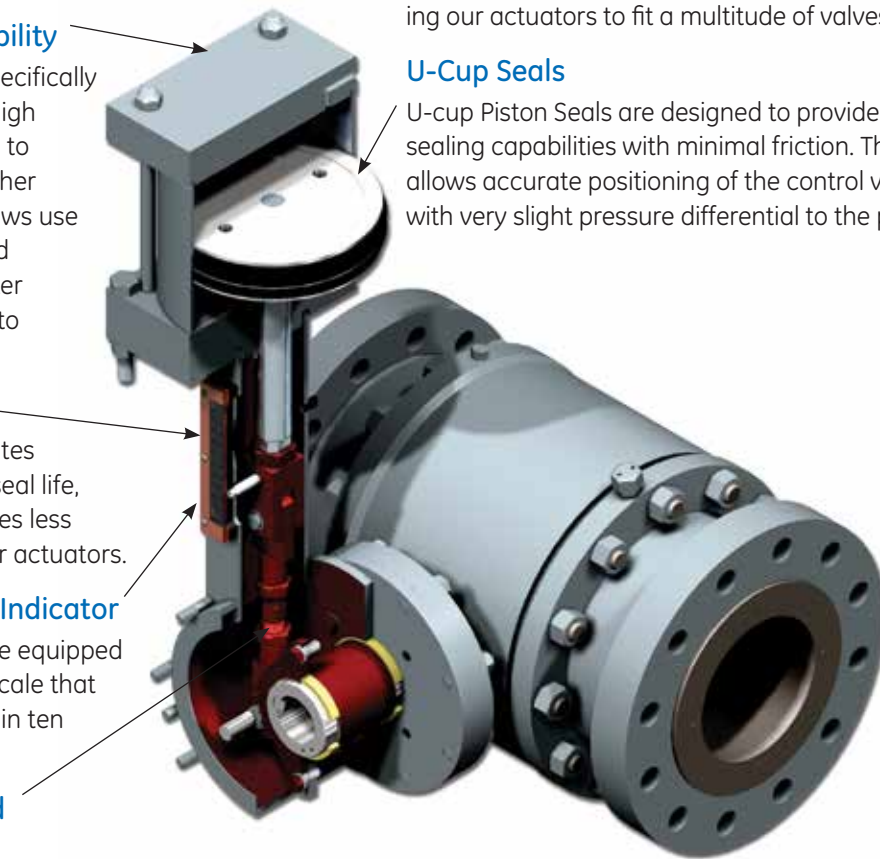

Figure 6 - Cutaway view of RPDA Actuator and Cylinder.

## Custom Coatings Available

Standard preparation of Becker RPDA actuators includes sandblast per SP-10 and epoxy coating for above ground actuators and coal tar epoxy for below ground actuator portions. RPDA actuators are available with custom coatings to suit application needs

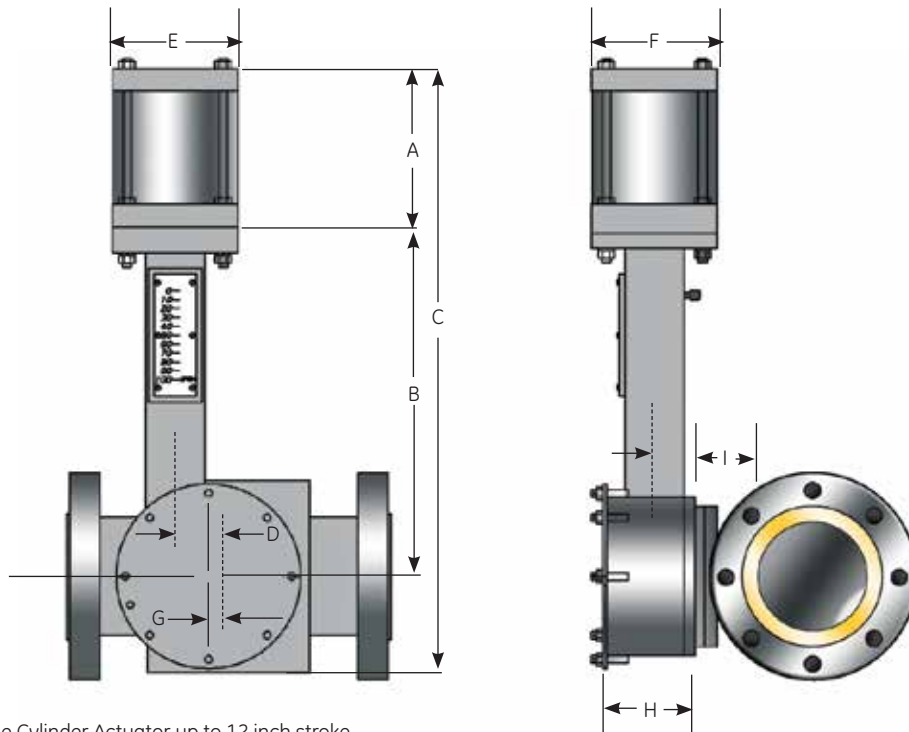

Figure 7 - RPDA Single Cylinder Actuator up to 12 inch stroke

Table 3 - RPDA Single Cylinder Actuator Dimensions up to 12 inch stroke

Model	Dimensions in inches (mm)									Weight	Volume
	A	B	C	D	E	F	G	H	I	lbs (kg)	in <sup>3</sup> (cm <sup>3</sup> )
4D	9.25 (235)	14.13 (359)	28.63 (727)	2.38 (60)	6.25 (159)	4.50 (114)	0.38 (10)	5.38 (137)	2.13 (54)	120.00 (54)	50.2 (823)
5D	9.56 (243)	14.13 (359)	28.94 (735)	2.38 (60)	7.63 (194)	5.50 (140)	0.38 (10)	5.38 (137)	2.13 (54)	125.00 (57)	78.5 (1,286)
6D	10.19 (259)	14.63 (371)	30.06 (764)	2.38 (60)	8.63 (219)	6.50 (165)	0.38 (10)	5.38 (137)	2.13 (54)	150.00 (68)	113.0 (1,852)
6F	12.19 (310)	18.19 (462)	34.81 (884)	3.63 (92)	6.50 (165)	6.50 (165)	1.38 (35)	7.00 (178)	2.75 (70)	210.00 (95)	169.6 (2,779)
8F	11.69 (297)	18.81 (478)	36.50 (927)	3.63 (92)	8.50 (216)	8.50 (216)	1.38 (35)	7.00 (178)	2.75 (70)	245.00 (111)	301.4 (4,940)
8H	13.06 (332)	19.81 (503)	36.75 (933)	4.75 (121)	8.50 (216)	8.50 (216)	1.50 (38)	7.00 (178)	2.75 (70)	295.00 (134)	401.9 (6,576)
8L	17.69 (449)	25.06 (637)	51.50 (1308)	7.25 (184)	8.50 (216)	8.50 (216)	4.00 (102)	8.50 (216)	3.50 (89)	440.00 (200)	602.9 (9,879)
10F	13.06 (332)	19.25 (489)	38.56 (979)	3.63 (92)	10.63 (270)	10.63 (270)	1.38 (35)	7.00 (178)	2.75 (70)	345.00 (157)	471.0 (7,718)
10H	15.06 (383)	20.25 (514)	42.44 (1078)	4.75 (121)	10.63 (270)	10.63 (270)	1.50 (38)	7.00 (178)	2.75 (70)	390.0 (177)	628.0 (10,291)
10L	19.06 (484)	25.50 (648)	53.31 (1354)	7.25 (184)	10.63 (270)	10.63 (270)	4.00 (102)	8.50 (216)	3.50 (89)	545.00 (247)	942.0 (15,437)
12L	19.06 (484)	25.50 (648)	53.81 (1367)	7.25 (184)	12.75 (324)	14.75 (375)	4.00 (102)	8.63 (219)	3.63 (92)	655.00 (297)	1846.3 (930,256)
14L	20.94 (532)	25.75 (654)	55.56 (1411)	7.25 (184)	14.75 (375)	14.75 (375)	4.00 (102)	8.63 (219)	3.63 (92)	850.00 (386)	1846.3 (30,256)

NOTE: Dimensions "B" and "C" will change for below ground units according to depth of burial



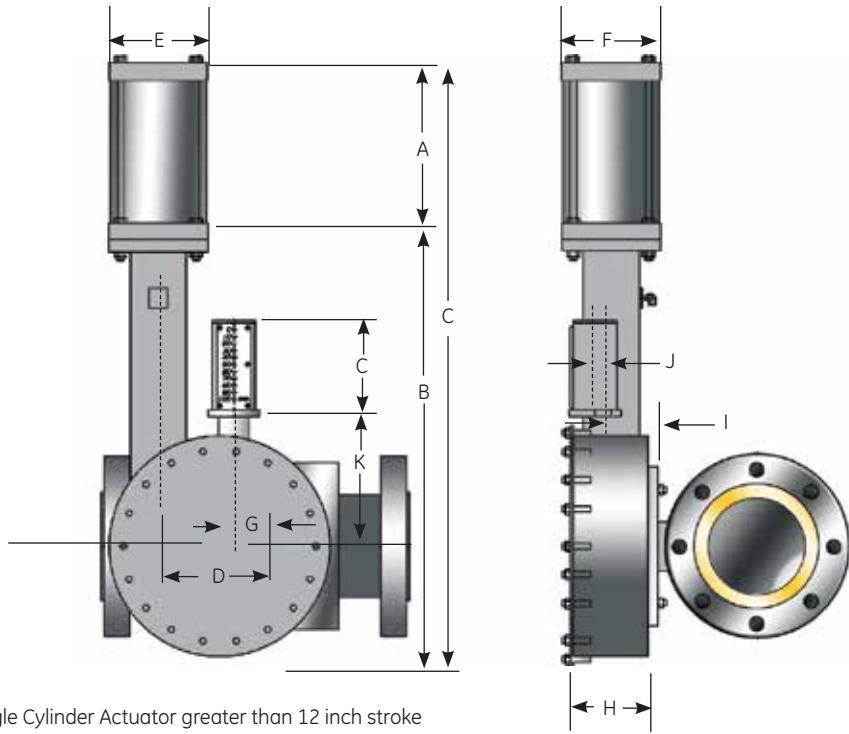

Figure 8 - RPDA Single Cylinder Actuator greater than 12 inch stroke

Table 4 - RPDA Single Cylinder Actuator Dimensions greater than 12 inch stroke

Model	Dimensions in inches (mm)												Weight	Volume
	A	B	C	D	E	F	G	H	I	J	K	L	lbs (kg)	in <sup>3</sup> (cm <sup>3</sup> )
<b>12T</b>	29.56 (751)	41.00 (1041)	86.56 (2199)	12.00 (305)	12.75 (324)	12.75 (324)	3.63 (92)	12.00 (3050)	5.00 (127)	3.75 (95)	20.00 (508)	9.56 (243)	985 (447)	2262.0 (37,068)
<b>12X</b>	33.56 (852)	47.63 (1210)	100.38 (2550)	14.50 (368)	12.75 (324)	12.75 (324)	3.63 (92)	12.00 (305)	5.00 (127)	3.75 (95)	20.00 (508)	9.56 (243)	1135 (515)	2715.0 (44,491)
<b>12Z</b>	35.56 (903)	48.63 (1235)	103.38 (2626)	15.75 (400)	12.75 (324)	12.75 (324)	3.63 (92)	12.00 (305)	5.00 (127)	3.75 (95)	20.00 (508)	9.56 (243)	1295 (588)	2941.0 (48,194)
<b>14T</b>	30.94 (786)	41.63 (1057)	88.31 (2243)	12.00 (305)	14.75 (375)	14.75 (375)	3.63 (92)	12.00 (305)	5.00 (127)	3.75 (95)	20.00 (508)	9.56 (243)	1165 (529)	3079.0 (50,456)
<b>14X</b>	34.94 (887)	48.00 (1219)	101.94 (2589)	14.50 (368)	14.75 (375)	14.75 (375)	3.63 (92)	12.00 (305)	5.00 (127)	3.75 (95)	20.00 (508)	9.56 (243)	1335 (606)	3695.0 (60,550)
<b>14Z</b>	36.94 (938)	49.00 (1245)	104.94 (2665)	15.75 (400)	14.75 (375)	14.75 (375)	3.63 (92)	12.00 (305)	5.00 (127)	3.75 (95)	20.00 (508)	9.56 (243)	1425 (647)	4003.0 (65,597)

**NOTE:** Dimensions "B" and "C" and "K" will change for below ground units according to depth of burial

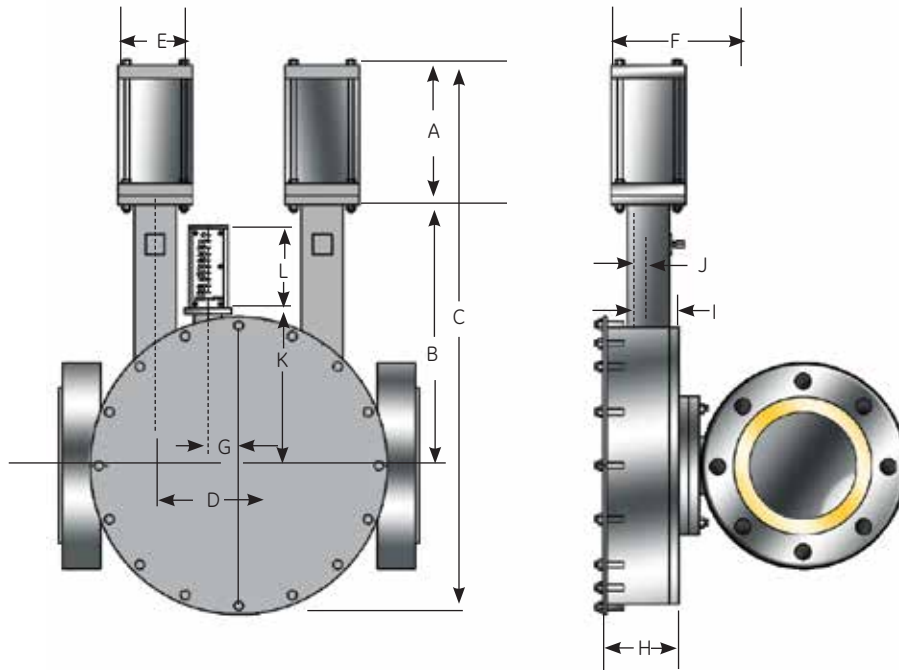

Figure 9 - RPDA Double Cylinder Actuator Dimensions greater than 12 inch stroke

Table 5 - RPDA Double Cylinder Actuator Dimensions greater than 12 inch stroke

Dimensions in inches (mm)													Weight	Volume
Model	A	B	C	D	E	F	G	H	I	J	K	L	lbs (kg)	in <sup>3</sup> (cm <sup>3</sup> )
D12T	29.56 (751)	41.00 (1041)	86.56 (2199)	12.00 (305)	12.75 (324)	12.75 (324)	3.63 (92)	12.00 (3050)	5.00 (127)	3.75 (95)	20.00 (508)	9.56 (243)	2097 (952)	4524 (74,135)
D12X	33.56 (852)	47.63 (1210)	102.19 (2550)	14.50 (368)	12.75 (324)	12.75 (324)	3.63 (92)	12.00 (305)	5.00 (127)	3.75 (95)	20.00 (508)	9.56 (243)	2375 (1078)	54300 (88,982)
D12Z	35.56 (903)	48.63 (1235)	106.19 (2697)	15.75 (400)	12.75 (324)	12.75 (324)	3.63 (92)	12.00 (305)	5.00 (127)	3.75 (95)	20.00 (508)	9.56 (243)	2565 (1165)	5882.0 (96,389)
D14T	30.94 (786)	41.63 (1057)	91.31 (2319)	12.00 (305)	14.75 (375)	14.75 (375)	3.63 (92)	12.00 (305)	5.00 (127)	3.75 (95)	20.00 (508)	9.56 (243)	2110 (958)	6158.0 (100,912)
D14X	34.94 (887)	48.00 (1219)	103.94 (2589)	14.50 (368)	14.75 (375)	14.75 (375)	3.63 (92)	12.00 (305)	5.00 (127)	3.75 (95)	20.00 (508)	9.56 (243)	2380 (1081)	7390.0 (121,100)
D14Z	36.94 (938)	49.00 (1245)	107.94 (2742)	15.75 (400)	14.75 (375)	14.75 (375)	3.63 (92)	12.00 (305)	5.00 (127)	3.75 (95)	20.00 (508)	9.56 (243)	2580 (1171)	8006.0 (131,195)

NOTE: Dimensions "B" and "C" and "K" will change for below ground units according to depth of burial

**Table 6** - Becker RPDA Actuator Selection Table

T-Ball Valve Size	500 (3447 kPa) = ΔP	1000 (6895 kPa) = ΔP	1500 (10342 kPa) = ΔP
	Double Acting	Double Acting	Double Acting
2" (50 mm)	5D	5D	5D
3" (80 mm)	5D	5D	6D
4" (100 mm)	6F	6F	6F
6" (150 mm)	8F	8F	8H
8" (200 mm)	10F	10F	10H
10" (250 mm)	10H	10H	10L
12" (300 mm)	10L	10L	12L
Temperature -20° F (-28.9° C) 100 psig (689 kPa) Power Gas			

T-Ball Valve Size	500 (3447 kPa) = ΔP	1000 (6895 kPa) = ΔP	1500 (10342 kPa) = ΔP
	Double Acting	Double Acting	Double Acting
2" (50 mm)	5D	5D	5D
3" (80 mm)	5D	5D	6D
4" (100 mm)	6F	6F	6F
6" (150 mm)	8F	8F	8H
8" (200 mm)	10F	10F	10H
10" (250 mm)	10H	10H	10L
12" (300 mm)	10L	10L	12L
Temperature -20° F (-6.7° C) 100 psig (689 kPa) Power Gas			

T-Ball Valve Size	500 (3447 kPa) = ΔP	1000 (6895 kPa) = ΔP	1500 (10342 kPa) = ΔP
	Double Acting	Double Acting	Double Acting
2" (50 mm)	5D	5D	5D
3" (80 mm)	5D	5D	6D
4" (100 mm)	6F	6F	6F
6" (150 mm)	8F	8F	8H
8" (200 mm)	10F	10F	10H
10" (250 mm)	10H	10H	10L
12" (300 mm)	10L	10L	12L
Temperature -20° F (-28.9° C) 125 psig (861 kPa) Power Gas			

T-Ball Valve Size	500 (3447 kPa) = ΔP	1000 (6895 kPa) = ΔP	1500 (10342 kPa) = ΔP
	Double Acting	Double Acting	Double Acting
2" (50 mm)	5D	5D	5D
3" (80 mm)	5D	5D	6D
4" (100 mm)	6F	6F	6F
6" (150 mm)	8F	8F	8H
8" (200 mm)	10F	10F	10H
10" (250 mm)	10H	10H	10L
12" (300 mm)	10L	10L	12L
Temperature -20° F (-6.7° C) 125 psig (861 kPa) Power Gas			

- Contact GE representative for valve sizes over 12" bore.
- T-Ball valves are comprised of the following: FPCV-T0, FPBV, QTCV-T1, QTCV-T2, and QTCV-T4
- For power gas pressures greater/less than 100 psig (689 kPa) contact GE.
- For higher ΔP applications contact GE representative.
- Power Gas =  $P_{supply} - P_{discharge}$  for applications that utilize Bleed to Pressure System™ Feature.

## Choose the Perfect Rotary Control Valve for your Application



### FPCV-T0 Series Full Port Control Valve:

- High turndown capability up to 100:1
- High pressure drop shutoff capability to Class VI



### QTCV-T1 Series Quiet Trim Control Valve:

- Noise attenuation up to 7 dBA
- High turndown capability up to 200:1
- High pressure drop shutoff capability to Class V



### QTCV-T2 Series Quiet Trim Control Valve:

- Noise attenuation up to 17 dBA
- High turndown capability up to 300:1
- High pressure drop shutoff capability to Class IV

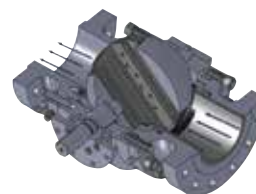

### QTCV-T4 Series Quiet Trim Control Valve:

- Noise attenuation up to 25 dBA
- High turndown capability up to 200:1
- High pressure drop shutoff capability to Class IV

**Table 7 - Becker RPDA Actuator Output Torque Table**

RPDA Actuator Model Number	Angular Position <sup>1</sup>	RDPA Actuator Output Torque/ Power Gas			MAOP <sup>3</sup>
		100 psig (689 kPa)	125 psig (862 kPa)	150 psig (1034 kPa)	
5D	Ending	3600 in-lb (24821 n-m)	4500 in-lb (31026 n-m)	5400 in-lb (37232 n-m)	500 psig (3447) kPa
	Running	5334 in-lb (36777 n-m)	6669 in-lb (45978 n-m)	8002 in-lb (55173 n-m)	
6F	Ending	7557 in-lb (52104 n-m)	9446 in-lb (65128 n-m)	11336 in-lb (78159 n-m)	500 psig (3447) kPa
	Running	11377 in-lb (78442 n-m)	14221 in-lb (98050 n-m)	17066 in-lb (117668 n-m)	
8F	Ending	13761 in-lb (94879 n-m)	17201 in-lb (118597 n-m)	20642 in-lb (142322 n-m)	500 psig (3447) kPa
	Running	20717 in-lb (142839 n-m)	25896 in-lb (178547 n-m)	31076 in-lb (214264 n-m)	
8H	Ending	18117 in-lb (124912 n-m)	22646 in-lb (156139 n-m)	27176 in-lb (187372 n-m)	500 psig (3447) kPa
	Running	26253 in-lb (181009 n-m)	32816 in-lb (226259 n-m)	39380 in-lb (271519 n-m)	
10F	Ending	21477 in-lb (148079 n-m)	26846 in-lb (185097 n-m)	32216 in-lb (222121 n-m)	500 psig (3447) kPa
	Running	32334 in-lb (222932 n-m)	40417 in-lb (278662 n-m)	48501 in-lb (334403 n-m)	
10H	Ending	28277 in-lb (194963 n-m)	35346 in-lb (243702 n-m)	42416 in-lb (292448 n-m)	500 psig (3447) kPa
	Running	40976 in-lb (282519 n-m)	51220 in-lb (353146 n-m)	61465 in-lb (423783 n-m)	
10L	Ending	41501 in-lb (286139 n-m)	51876 in-lb (357672 n-m)	62252 in-lb (429212 n-m)	500 psig (3447) kPa
	Running	61222 in-lb (422109 n-m)	76527 in-lb (527634 n-m)	91833 in-lb (633169 n-m)	
12L	Ending	58760 in-lb (405136 n-m)	73450 in-lb (506420 n-m)	88140 in-lb (607704 n-m)	400 psig (2758 kPa)
	Running	93781 in-lb (646595 n-m)	117226 in-lb (808244 n-m)	140671 in-lb (969893 n-m)	
14L	Ending	79642 in-lb (549112 n-m)	99553 in-lb (686394 n-m)	119463 in-lb (823668 n-m)	400 psig (2758 kPa)
	Running	127108 in-lb (876381 n-m)	158886 in-lb (1095481 n-m)	190662 in-lb (1314571 n-m)	
12T	Ending	100412 in-lb (692316 n-m)	125515 in-lb (865395 n-m)	150618 in-lb (1038475 n-m)	400 psig (2758 kPa)
	Running	156116 in-lb (1076381 n-m)	195145 in-lb (1345476 n-m)	234174 in-lb (1614571 n-m)	
12X	Ending	120017 in-lb (827488 n-m)	150021 in-lb (1034358 n-m)	180026 in-lb (1241236 n-m)	400 psig (2758 kPa)
	Running	187277 in-lb (1291230 n-m)	234096 in-lb (1614035 n-m)	280916 in-lb (1936851 n-m)	
14T	Ending	136093 in-lb (938328 n-m)	170116 in-lb (1172908 n-m)	204140 in-lb (1407496 n-m)	400 psig (2758 kPa)
	Running	211591 in-lb (1458868 n-m)	264488 in-lb (1823582 n-m)	317387 in-lb (2188307 n-m)	
14X	Ending	162665 in-lb (1121536 n-m)	203331 in-lb (1401918 n-m)	243998 in-lb (1682307 n-m)	400 psig (2758 kPa)
	Running	253826 in-lb (1750068 n-m)	317282 in-lb (2187583 n-m)	380740 in-lb (2625108 n-m)	
14Z	Ending	174886 in-lb (1205796 n-m)	218608 in-lb (1507249 n-m)	262329 in-lb (1808695 n-m)	400 psig (2758 kPa)
	Running	275168 in-lb (1897216 n-m)	343961 in-lb (2371525 n-m)	412752 in-lb (2845824 n-m)	
D12T	Ending	200824 in-lb (1384633 n-m)	251030 in-lb (1730791 n-m)	301236 in-lb (2076949 n-m)	400 psig (2758 kPa)
	Running	312232 in-lb (2152761 n-m)	390290 in-lb (2690951 n-m)	468347 in-lb (3229142 n-m)	
D12X	Ending	240034 in-lb (1654976 n-m)	300043 in-lb (2068724 n-m)	360051 in-lb (2482464 n-m)	400 psig (2758 kPa)
	Running	374554 in-lb (2582460 n-m)	468194 in-lb (3228081 n-m)	561831 in-lb (3873690 n-m)	
D12Z	Ending	258066 in-lb (1779302 n-m)	322583 in-lb (2224131 n-m)	387099 in-lb (2668954 n-m)	400 psig (2758 kPa)
	Running	406044 in-lb (2799577 n-m)	507556 in-lb (3499477 n-m)	609067 in-lb (4199366 n-m)	
D14T	Ending	272187 in-lb (1876663 n-m)	340234 in-lb (2345831 n-m)	408281 in-lb (2814998 n-m)	400 psig (2758 kPa)
	Running	423183 in-lb (2917747 n-m)	528980 in-lb (3647186 n-m)	634776 in-lb (4376626 n-m)	
D14X	Ending	325331 in-lb (2243078 n-m)	406664 in-lb (2803849 n-m)	487997 in-lb (3364621 n-m)	400 psig (2758 kPa)
	Running	507653 in-lb (3500147 n-m)	634567 in-lb (4375187 n-m)	761481 in-lb (5250226 n-m)	
D14Z	Ending	349772 in-lb (2411593 n-m)	437215 in-lb (3014491 n-m)	524658 in-lb (3617389 n-m)	400 psig (2758 kPa)
	Running	550336 in-lb (3794431 n-m)	687920 in-lb (4743039 n-m)	825504 in-lb (5691647 n-m)	

**NOTES:**

1. See graph to right.
2. Power Gas = Psupply when discharge (vent to atmosphere).
3. Power Gas = Psupply- Pdischarge when utilizing Bleed to Pressure System™ feature.
4. Consult Becker when Psupply > 150psig to ensure satisfactory operation

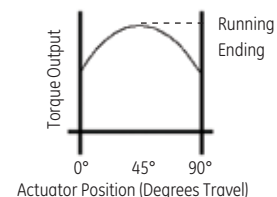

## Below Ground Regulator Options

The Becker Below Ground Ball Valve Regulator option is unique to GE and provides a multitude of benefits by direct burial of the control valve. The valve actuator, lubrication lines, and drain lines are extended above ground while the ball valve remains below ground. The primary advantage of Becker Below Ground Regulators is inexpensive noise attenuation in excess of 25 dBA.

- More than 25 dBA noise attenuation
- Less ambient heat loss
- May use smaller adjacent piping diameter
- Smaller station footprint
- Most economical noise attenuation
- May eliminate need for buildings/enclosures by utilizing the fiberglass cabinet



**Figure 11** - Installation of Becker Below Ground Regulators (Prior to Backfill) A large natural gas transmission/distribution company based in Southern California installed Becker Below Ground Ball Valve Regulators to achieve maximum noise attenuation, minimal maintenance, and optimum cost effectiveness. The Below Ground Regulator can provide up to 37 dBA additional noise attenuation with minimal additional cost. Two different size Below Ground Ball Valve Regulators are shown here. 16" Bore Below Ground Regulators are shown in background, while 30" bore Below Ground Ball Valve Regulators are shown in foreground. The Below Ground Ball Valve Regulators are shown during installation, prior to backfill of the regulator station.

## Additional Noise Attenuation

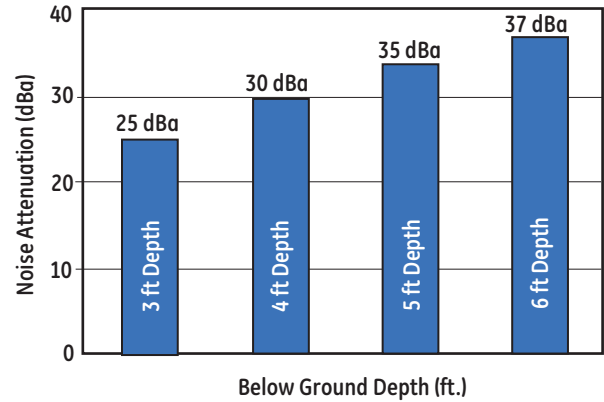

**Figure 10** - Below Ground Noise Attenuation Compared to Depth. Typical below ground depths range from 3 feet to 6 feet burial. The below ground depth is measured from centerline of pipe to ground. Below ground usually provides from 25 dBA to 37 dBA noise attenuation



**Figure 12** - Installation of Becker Below Ground Regulators (After Backfill)

The customer was able to achieve up to 25 dBA noise attenuation over conventional above ground control valves with minimal costs. The RPDA actuator utilizes an extended linkage to throttle the control valve below ground. Many GE customers have utilized the below ground concept for many years with great success and minimal maintenance. The topworks of the control valve actuators are enclosed with Becker CAB Series Fiberglass Cabinets (green) after backfill of regulator station. 16" Below Ground Ball Valve Regulators are located at left, while 30" Below Ground Ball Valve Regulators are located at right. A masonry wall has been installed at the perimeter of the station. Upstream station isolation valves are located in the foreground of the picture.



# Accessories

GE's Becker Control Valve Actuators provide reliability and accuracy for all of your control valve applications



## Limit Switches

Limit switches provide an indication of valve status and are commonly utilized on both on-off and control valves. A limit switch assembly will close a contact at both the full-open and at the full-closed position of valve travel. The switches provide a remote indication to gas control, RTU or a flow computer as to the status of a valve. Limit switch assemblies are available with a variety of configurations.

<b>Housing</b>	NEMA 4, 4X, 7, Class I, Groups C & D, Division 1 & 2	<b>SPDT</b>	Single Pole, Double Throw
<b>Switches</b>	2 or 4	<b>DPDT</b>	Double Pole, Double Throw up to 125 V D.C. at .5 amps
<b>Option</b>	2 or 4 Hermetically Seales Switches		up to 250 V A.C. at 15 amps



## Position Transmitter

The Valve Position Feedback assembly provides a quantitative indication of the exact position of a control valve. The Valve Position Feedback assembly provides 4-20 mA analog remote position feedback proportional to the control valve position. The feedback signal may be utilized as an integral portion of the control loop or merely as an additional feedback signal to gas control for monitoring valve status. Valve Position Feedback is typically utilized on flow control valves

<b>Transmitter</b>	4-20 mA Output	<b>SPDT</b>	Single Pole, Double Throw
<b>Housing</b>	NEMA 4, 4X, 7, Class I, Groups C & D, Division 1 & 2	<b>DPDT</b>	Double Pole, Double Throw up to 125 V D.C. at .5 amps
<b>Switches</b>	2 or 4		up to 250 V A.C. at 15 amps
<b>Option</b>	2 or 4 Hermetically Seales Switches		



## Trip Valve

The Trip Valve protects double-acting actuators from loss of supply gas pressure. In the event that the supply gas pressure falls below a minimum level, the trip valve can be configured to do one of the following: lock the valve in last position, stroke the valve to the full-open position\*, Stroke the valve to the full-closed position\*

\*These applications require an additional volume tank to perform the operation

<b>Max Allowable</b>	150 psig 91034 kPa)	<b>Trip Point</b>	Adjustable from 40 psig (276 kPa) to 70% of supply pressure
<b>Weight</b>	4.5 lbs (2.0 kg)	<b>Volume Tank</b>	Required for fail-open or fail-closed modes. DOT approval LP Tank (240 psig (1655 kPa) Max with DOT Stamp). Size based on application
<b>Body Connections</b>	1/4" FNPT		
<b>Temp. Limits</b>	-40°F to + 180 F (-40°C to +82°C)		



## Hydraulic Operator override

The Hydraulic pump override is utilized for manual operation of large control valves when pneumatic power is not available. The Hydraulic pump override utilizes a hydraulic pump and reservoir to develop necessary torque to close/open the control valve. Hydraulic pump overrides are typically utilized on ball control valves larger than 16" bore.

## Let GE help select the perfect rotary control valve actuator

Table 8- Selection table for Becker Control Valves and Actuators

	RPDA (Small Models)	RPDA (Large Models)	SYDA (Small Models)	SYDA (Large Models)	RPSR	SYSR	LPDA (Small Models)	LPDA (Large Models)	LPSR	LD
<b>Actuator Instrumentation</b>										
VRP-CH-Pilot	•	•	•	•			•	•		
VRP-B-CH Pilot	•		•							
VRP-SB-CH-Pilot					•	•			•	•
VRP-SB-PID Pilot					•	•			•	•
HPP-4 Positioner	•	•	•	•			•	•		
HPP-5 Positioner	•		•				•			
HPP-SB Positioner					•	•			•	•
DNGP Positioner	•	•	•	•	•	•	•	•	•	•
VRP-SB-GAP	•	•	•	•	•	•	•	•	•	•
<b>Compatible Valves</b>										
FPCV-T0	•	•	•	•	•	•				
QTCV-T1	•	•	•	•	•	•				
QTCV-T2	•	•	•	•	•	•				
QTCV-T4	•	•	•	•	•	•				
Globe Series							•		•	•
<b>Actuator Options</b>										
Bleed to Pressure System BPS™	•		•	•		•	•	•	•	
AB Series Atmospheric Bleed Control	•		•	•		•	•	•	•	
NBV Series No-Bleed Valve	•	•				•	•			
DPS-2 Series Non-Bleed Sensor	•	•				•	•			
PS-2 Series Non-Bleed Sensor	•					•				
SP Series Setpoint Pump	•	•	•	•	•					
RSM Series Remote Setpoint Module	•	•	•	•	•					
Panel Mounting	•	•	•	•	•					•
Stainless Steel Option	•	•	•	•	•	•	•	•		
VB Series Volume Booster	•		•		•	•		•		
QEV Series Quick Exhaust Valve				•				•		
I/P Transducer						•	•	•		
SLV Series Signal Lock Valve						•	•	•		

1. RPSR, SYDA, and LPDA Small Models are defined as actuator size <2000 in<sup>3</sup> (0.333m<sup>3</sup>).
2. RPSR, SYDA, and LPDA Large Models are defined as actuator size >2000 in<sup>3</sup> (0.333m<sup>3</sup>).
3. LD Series Actuators are limited to Becker Series Globe Valves
4. BPS™ is limited to discharge pressure systems below 300 psig (2068 kPa). Consult Becker for application assistance.

**\*CAUTION:** This information is intended as a guideline for application of Becker Control Valve products. GE strongly recommends consulting Becker product Engineering prior to application of any product.

GE has a wide variety of control valve actuators with a variety of features that ensure the optimum solution for your application needs. Refer to the figures to the left to assist you in selecting the proper control valve actuator and accessories.



Figure 13 - Becker RPDA Rotary Piston Double Acting Actuator

The Becker RPDA Actuator is a rugged, quarter-turn actuator design for the rigors of aggressive throttling service. The RPDA features a high pressure crank-arm design specifically geared for control valve service. The high pressure capability of the RPDA allow power gas pressures up to 500 psig. This extended power gas range permits the implementation of GE's unique "bleed to pressure system" that eliminates all atmospheric emissions. Additionally, the RPDA is available with a Below Ground Option to substantially reduce noise with minimal additional expense.

