

New Cross Head Design

Benefits

- ■ ■ Increased production
- □ □ Higher efficiency
- □ □ Compliance with environmental regulations
- ■ ■ Availability and Reliability
- □ □ Life extension

Customer benefits include:

- Rod load increase
- Greater connection rod fatigue resistance
- Increased bearing load capacity
- Improved safety

What it is

The GE Oil & Gas API 618 reciprocating compressor line was enhanced in 2003 by upgrading key components. The rod load was updated using a conservative design approach based on the following principles:

- Leveraging of the GE's extensive field experience
- Rigorous design using proven, advanced methodologies
- Validation of the stress state of new components through a full-scale strain gage test campaign
- Application of proven allowable design limits based on previous designs and experience
- Limiting the use of new components

- Providing an uprate path for existing units by controlling the geometry for interchangeability of new and original components
- Improved manufacturability

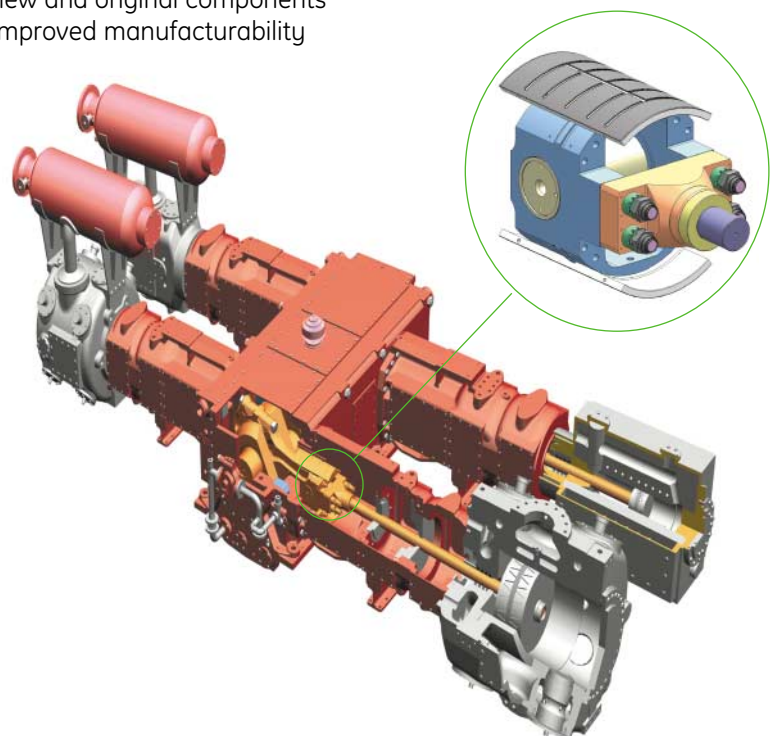

What it is

GE's patented new crosshead design is based on the same very compact concept used in the SHM compressor model high-speed API 618 machines. As of 2003, there have been more than two hundred of these crossheads in operation, some since the early nineties. Their track record has been excellent, with not a single damage event. The uprate is primarily associated with the design of the

crosshead and the related piston rod attachment. Key features of the new crosshead design are:

- The piston rod is attached to a flange by means of a hydraulically tightened threaded connection
- Four bolts clamp the flange, the crosshead body and the crosshead pin together. The crosshead body of the uprated machines is made from a forged steel bar

- The ballast used to equalize the reciprocating masses of the two opposing crank-throws is divided into two pieces which are separately attached to the crosshead. The reduced weight of the individual components improves the maintenance process
- The crosshead shoes are interchangeable with the previous design

How it works

Connecting rod fatigue resistance has been improved by shot peening the surface of the small end bore. Al-Sn (Aluminium-Tin) bi-metallic bearings have been introduced for the HG, HF, HE and HD models. Tri-metallic bearings have been introduced on the HB and HA models. Their load capacity is much higher than the previous bearings and consequently their use provides an extra safety factor even though the rod load limit has been increased. An improved connecting rod bolt material and preload were introduced on HA, HB and SHM/B frames to increase the safety factor for separation between conrod components.

Improvement	HG	HF	HE	HD	HB	HA	SHM/B
Crosshead design	√	√	√	√	√	√	√
Shot peening of connecting rod	√	√	√	√	√	√	√
AlSn shell bearings	√	√	√	√			
Improved crankshaft material			√		√	√	
Improved conrod bolt material					√	√	√
Tri-metal shell bearing					√	√	

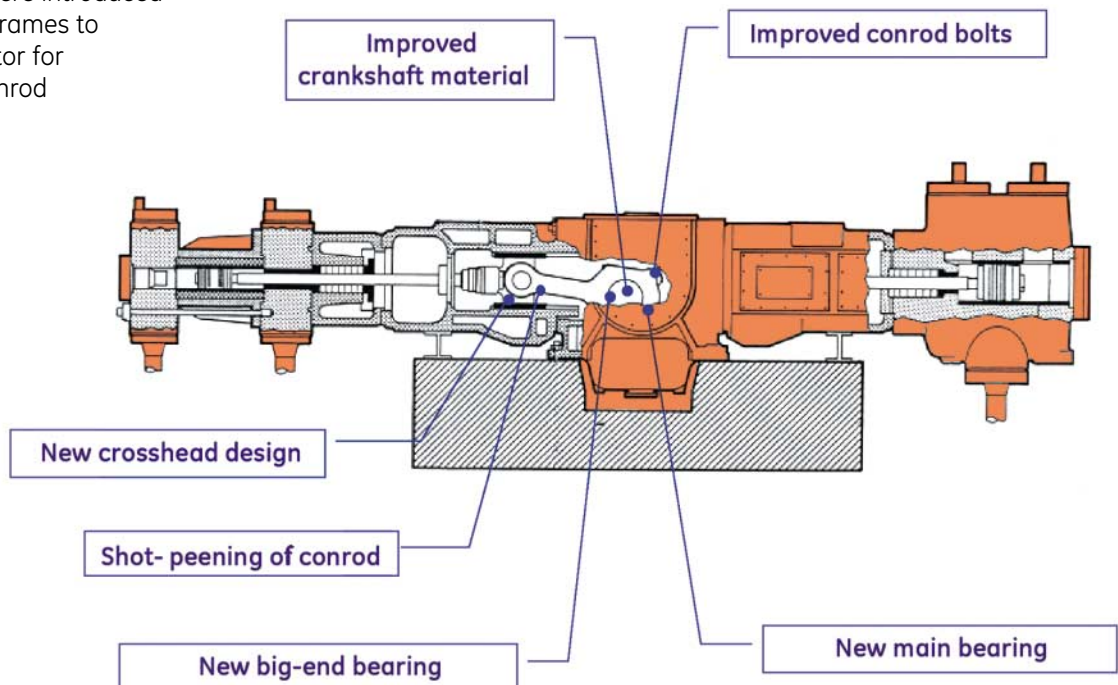

Nuovo Pignone S.p.A.
 via F. Matteucci, 2
 50127 Florence - Italy
 T +39 055 4272500
 F +39 055 4232800
 E customer.service.center@ge.com
 www.ge.com/oilandgas

COMK/MARK 839/II - Designed by: Studio Tre Fasi
 Printed by: Sagraf - 1-2007
 ©2007 Nuovo Pignone S.p.A. all rights reserved